

MALE END VIEW

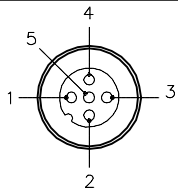

- 1 = BROWN
- 2 = WHITE
- 3 = BLUE
- 4 = BLACK
- 5 = GRAY



SPECIFICATIONS

CONTACT CARRIER MATERIAL	NYLON OR TPU
MOLDED HEAD MATERIAL/COLOR	TPU/YELLOW
CONTACT MATERIAL/PLATING	BRASS/GOLD
COUPLING NUT MATERIAL/PLATING	BRASS/NICKEL
RATED CURRENT [A]	4.0 A
RATED VOLTAGE [V]	250 V
OUTER JACKET MATERIAL/COLOR	TPU/GRAY
CONDUCTOR INSULATION MATERIAL	PVC
NUMBER OF CONDUCTORS [AWG]	5x22 AWG
TEMPERATURE RANGE	-40°C to +90°C (-40°F to +194°F)
PROTECTION CLASS	NEMA 1,3,4,6P AND IEC IP68, IP69K

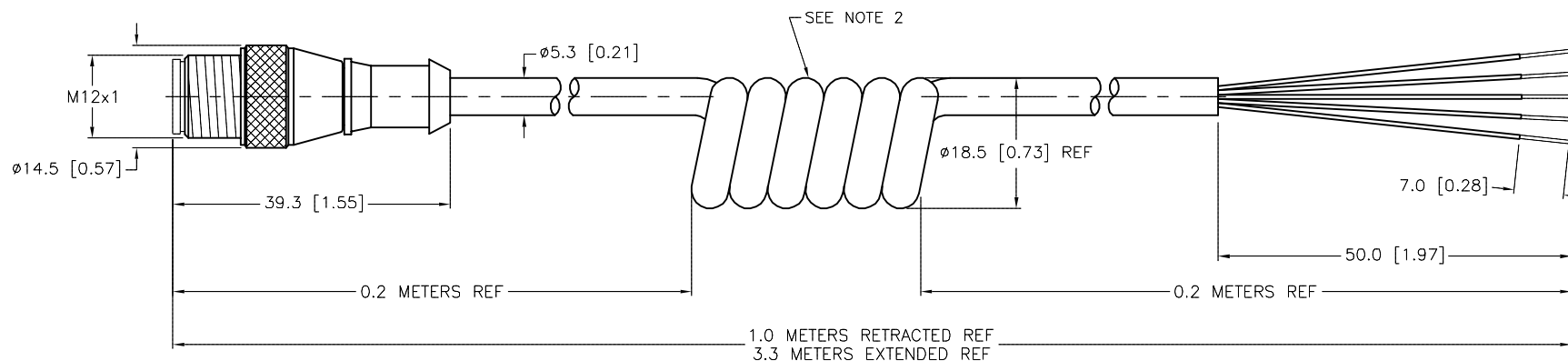

SOURCE DRAWING - FOR REFERENCE ONLY

NOTES:

- 1. "/S90" DESIGNATES THERMOPLASTIC POLYURETHANE (TPU) CABLE.
- 2. NUMBER OF COILS IS REFERENCE ONLY.

RELATED DOCUMENTS		3RD ANGLE PROJECTION		THIS DRAWING IS CONFIDENTIAL AND THE PROPERTY OF TURCK INC. USE OF THIS DOCUMENT WITHOUT WRITTEN PERMISSION IS PROHIBITED.		<b>TURCK INC</b> High Technology Sensors and Automation Controls 3000 CAMPUS DRIVE MINNEAPOLIS, MN 55441 1-800-544-7769 (763) 553-7300 (763) 553-0708 fax turck.com	
1. 2. 3. 4.				DRFT RWC		DATE 02/21/07	
MATERIAL		ALL DIMENSIONS DISPLAYED ON THIS DRAWING ARE FOR REFERENCE ONLY		APVD		SCALE 1=1.0	
SEE SPECIFICATIONS		CONTACT TURCK FOR MORE INFORMATION		UNIT OF MEASUREMENT		DESCRIPTION	
FINISH		MILLIMETER [ INCH ]		DO NOT SCALE THIS DRAWING		RS 4.5T-3.3/S90-SP	
SEE SPECIFICATIONS						IDENTIFICATION NO. U0874-09	
						REV G	
G UPDATE CABLE DIAMETER		RDS 11/20/13 43834		FILE: U0874-09		SHEET 1 OF 1	
REV DESCRIPTION		BY DATE ECO NO.					